

PORTABLE POWER STATION M2200

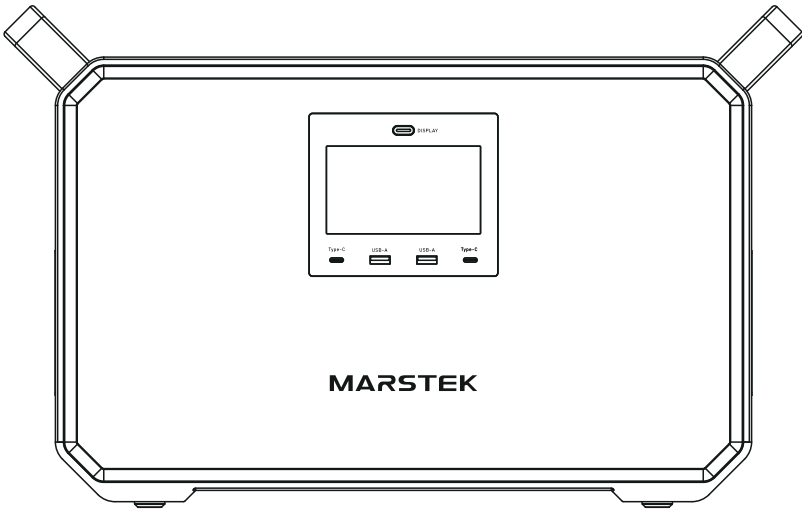

CONTENTS

Product description	1
Specifications	3
Operating temperature range	3
Chargeable device	4
Charging Method	5
Use Instructions	5
Troubleshooting	6
LED Screen Instructions	6
APP Instructions	6
Frequently Questions & Answers	8
Packing list	9
Warranty and Contact Information	9
Chemical Composition of Toxic and Harmful Substances	9
Important safety information	10

Important! This product manual is for the energy storage system product with an AC output range of 200V-240V/50Hz. Please refer to the actual product for the specific specifications and parameters. Before using this product, please read this manual carefully.

Product description

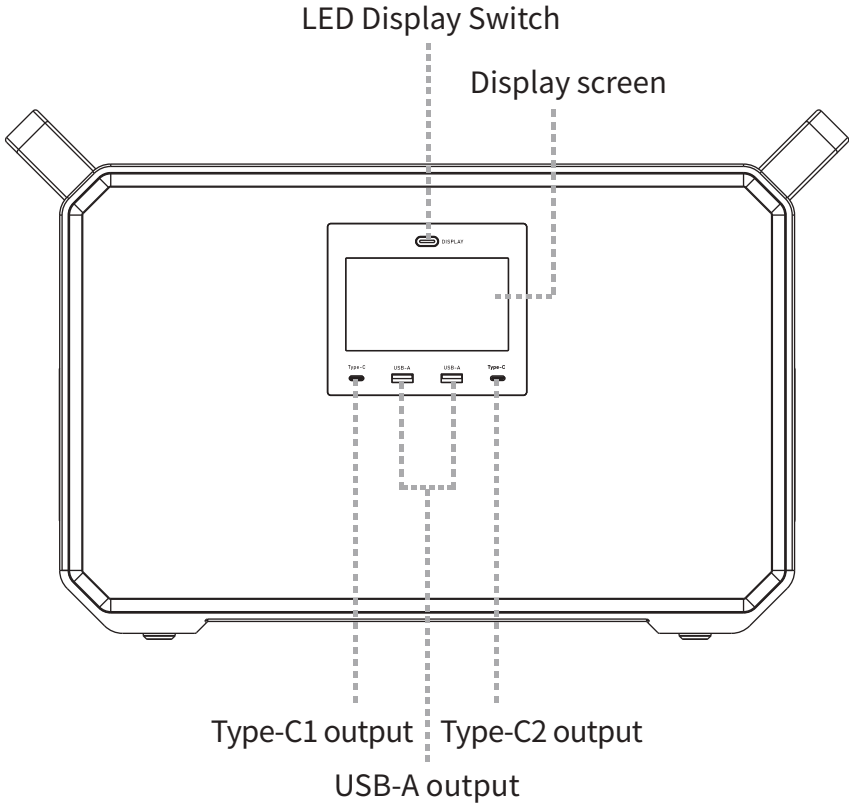

LED Display Switch

1. Light press to turn on/off the LED display.
2. Long press to reset Bluetooth pairing information.

Input

1. Supports AC input up to 2000W.
2. Supports solar energy input via XT60 up to 600W*2.
3. Supports vehicle input up to 120W.

Product description

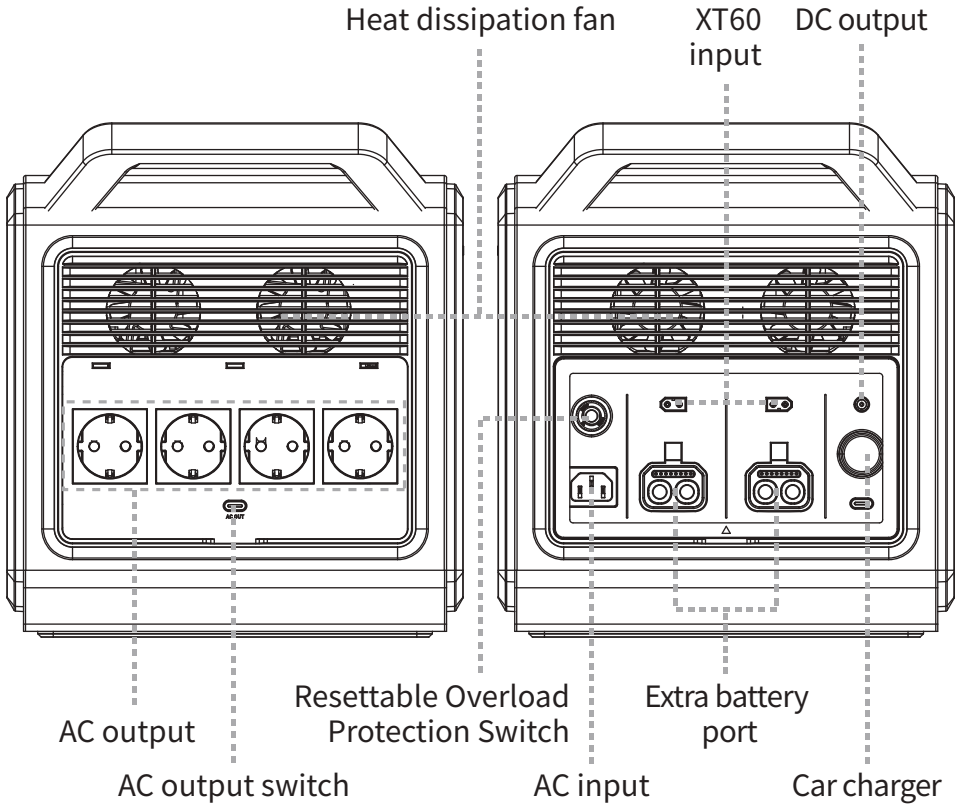

















Output





1. Type-C1 output supports up to 100W.
2. Type-C2 output supports up to 45W.
3. USB-A (x2) output supports up to 18W each.
4. Car charger/DC output supports up to 12V/10A (shared).
5. AC (x2) output supports rated 2400W, peak 4800W.

*Extra battery need to buy separately

Specifications

					
Capacity	Weight	Dimension	Battery Cell	Bluetooth	Certificate
2240Wh (50000 mAh/ 44.8V)	26.7±0.5 kg	495.6x276x311mm	LiFePO4	Bluetooth 4.2	  RoHS 

						
XT60 Input	AC Input	Car charger Output	DC Output	Type-C Output	USB-A Output	AC Output
600W*2 (12-59V)	2000W max.	120W max.		1:PD100W 2:PD45W	18W max.	2400W

				
Cycle times	Storage Temperature	Operation Temperature	Charging Temperature	Protect system
6000times (25°C)	-10 - 45°C	-10 - 40°C	0 - 40°C	Overcharge protection, Over-discharge protection, Overcurrent protection, Over temperature protection, Short circuit protection, Overvoltage protection.

Operating temperature range

Low temperatures may affect the product's battery capacity. The product can be charged within a temperature range of 0°C to 40°C. If you are charging under freezing conditions, we recommend storing the product in an insulated cooler or other temperature-controlled environments and connect it to a power source (AC output socket, solar photovoltaic panel). The product can charge devices within a temperature range of -10°C to 40°C.

Chargeable device

USB Output: Smartphone, Smartwatch, Digital Camera, E-reader, Tablet, etc.

12V Car charger Outlet: Light, Car Adaptor, etc.

AC Output: Laptop, LED screen, Household appliances, etc.

AC Output:



LED lights
12V/5W
(380 h)



Camera
16WH
(119 times)



Laptop
60WH
(31 times)



Drone
60WH
(31 times)



Fan
45W
(42 h)



TV
110W
(17 h)



Wall breaking
machine
400W (4.5 h)



Electric
cooker
800W (2.2 h)



Projector
100W
(19 h)

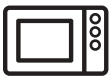

Electric oven
1500W
(1.2 h)



Electric Drill
1000W
(1.9 h)



Hair Dryer
1200W
(1.6 h)

EN

USB Output:



iPhone 15
3349mAh
(144 times)



Nintendo Switch
4310mAh
(119 times)



Ipad pro2021
28.65Wh
(66 times)

DC Output:



Car charger Outlet Car refrigerator
65W
(29 h)

Charging Method

Before using or storing the product, please charge it with the power cord. When charging from the mains, the LED screen will light up and display the current battery level. A 100% display on the LED screen indicates a full charge.

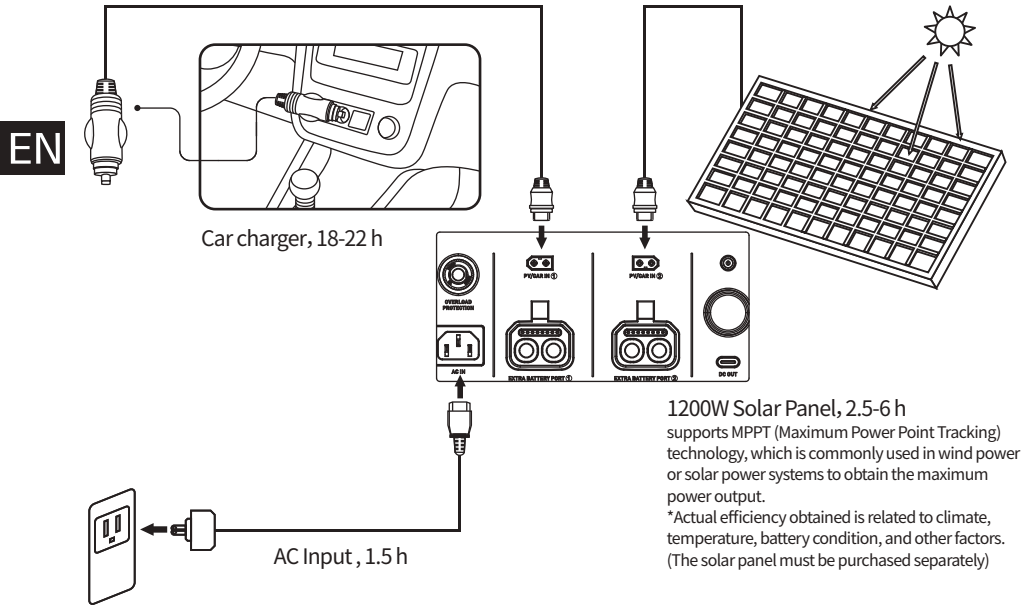

Use Instructions

How to use it:

1. Press the power switch next to each port you are going to use.
2. When the indicator light next to the port is on, the output port is activated and can power the corresponding device.
3. The AC output port is rated for a maximum of 2400W (peak 4800W). If the product is used beyond the maximum power, the over-power protection will activate, and the AC output will shut off. Press the button to reactivate after the load is removed.
4. The AC output port will shut off after 2 hours of no load, and the DC output port will shut off after 12 hours of no load.
5. If the product is not used for a long time, it is recommended to replenish the charge every 3 months, maintaining the battery level between 60%-80%, and store it in a cool and dry place.

Note: Please press the power button to turn it off when not using the AC power port to save power.

Troubleshooting

If your device does not successfully charge with this product, please follow these steps:

1. Ensure that the output port is open and the LED indicator on the power button is lit.
2. Check the LED battery display; if it is at 20% or below, please charge the product.
3. The power of the device you are using exceeds the maximum power supply capacity of the product's port.
4. The connection cable of the device you are using is not properly plugged in or has poor contact.

EN

LED Screen Instructions

The LED screen of this product displays the product usage status. When any function is activated, the screen will light up. When the screen display is not needed, you can press the button to turn off the LED screen.

- 1.Expansion pack
- 2.Overcharge alarm
- 3.Bluetooth status display
- 4.WIFI status display
- 5.Timing function
- 6.AC charge Power
- 7.Solar charge power
- 8.AC output power
- 9.DC output power
- 10.Power display

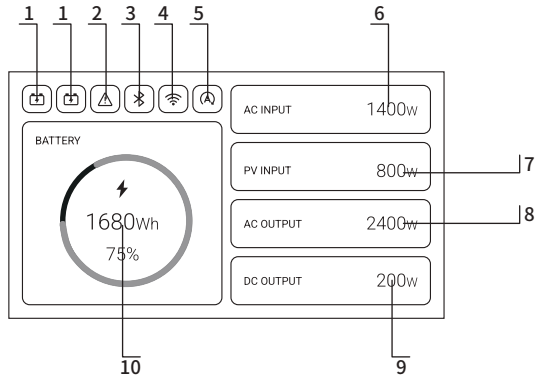

APP Instructions

MARSTEK APP can connect to all your devices via Bluetooth or WI-FI, track your energy usage and production in real time, dynamically display the status data of your devices, and keep control of your device's energy in your own hands. This software can run on phones with Android 6.0 and iOS 12.0 or above versions.

Software Installation

. Scan the QR code to install and open the application on your smartphone.



Login

. After installation is complete, users can click the desktop icon to enter the login interface. The first time it is opened, it will enter the server switch interface.

. Choose to register an account, and register, log in, and set a password according to the page prompts.

. Click on the top right corner of the login interface -> to enter the server selection interface, and select according to different regions. If the wrong server is selected, the application will not be able to retrieve device history data.

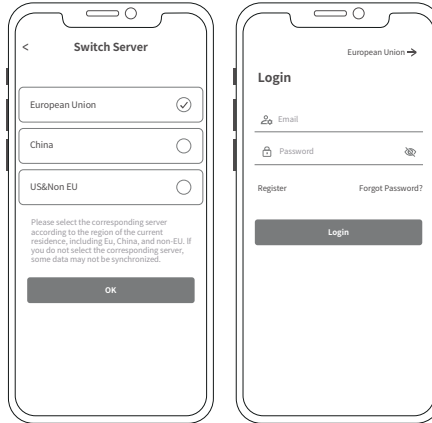

Add Device

. After successful login, select "Add Device" in the upper left corner to add a device.

. Turn on Bluetooth® and location sharing on your smartphone, and select to add the device directly.

. After the device is successfully added, the device name will be displayed on the start page.

. Click on different devices on the device management page to switch to different devices. On the IOS system, swiping left will trigger modification and deletion of devices. On the Android system, long-pressing the device list will trigger modification and deletion of devices.

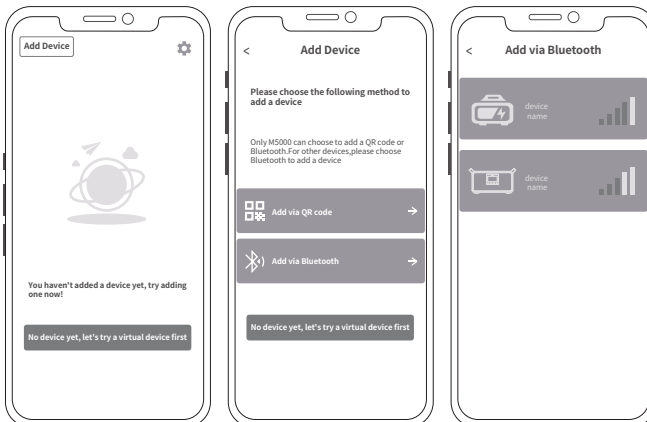

Home Screen of Device

Real-time display of device status: alarms, fan status, Bluetooth WIFI status, battery remaining, DC/AC output power, PV/AC input power.

APP Settings

Select the settings wheel at the top right to change settings or get information:

- . Account management.
- . Set AC idle standby time.
- . Set DC idle standby time.
- . Share device.
- . Wireless network settings.
- . APP and device information.



EN

Frequently Questions & Answers

Q:What is the battery type?
LiFePO4 Battery.

Q: Can the product be taken on the aircraft?
No, according to the airline transportation standards, 100Wh capacity of lithium battery can not board the aircraft.

Q: How to determine the current status of the product?
The LED display of this product can help you better understand the power source and monitor power consumption. The IN (input) end reflects the power when the product is charging. The OUT (output) end represents the real-time output power of the device you have plugged in. You can judge how long the product can work by the percentage of power on the display.

Packing list

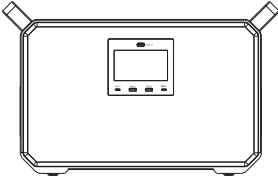

M2200

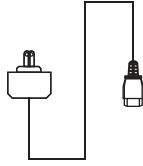

AC charger cable

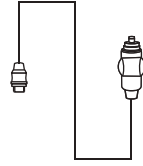

Car charging cable

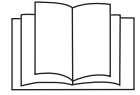

User Manual

EN

Warranty and Contact Information

Under normal use of the product, it will not affect the result of defective workmanship and materials used in the product: This warranty period describes the complete and exclusive warranty obligations of the product, and we will not assign or authorize anyone to be responsible for any other products.

warranty period

Product warranty period of 5 years. In all cases, the warranty period starts from the date of purchase by the consumer. In order to ensure the start date of the warranty period, the consumer needs to provide proof of purchase or other reasonable supporting documents.

The following conditions are not covered by the warranty

- 1.The appearance of the product is damaged after use.
- 2.Unauthorized disassembly and maintenance of non-professionals.
- 3.Performance problems caused by human factors.
- 4.Damage caused by natural disasters, lightning Strikes, accidents and other irresistible factors.

How to get warranty service

You can contact our customer service through our official website or e-commerce platform. Thank you for your cooperation!

Chemical Composition of Toxic and Harmful Substances

Part Name	Toxic and harmful substances or chemical elements						O: The content of hazardous substances in homogeneous materials all components are limit requirement specified in GB-T 26572. X: The content of hazardous substance in at least one of the average materials of the part exceeds the limit requirement of GB-T 26572, and there is no mature alternative in the industry at present, which meets the environmental protection requirements of the EU RoHS directive.
	Pb	Hg	Cd	Cr(VI)	PBB	PBDE	
Product shell	0	0	0	0	0	0	
Circuit module	X	0	0	0	0	0	
button	0	0	0	0	0	0	
Small hardware	0	0	0	0	0	0	
Charging Cable	0	0	0	0	0	0	
Battery	0	0	0	0	0	0	

This information for reference purposes only and does not represent a binding agreement. Product (Color, Size, OSD, etc.) in kind prevail.

Important safety information

Warnings!

Please notice the following safety precautions carefully. If physical injury, loss of data, or damage is caused by failure to follow instructions, the warranty does not apply.

- To reduce the risk of injury, close supervision is necessary when the product is used near children.
- Do not put fingers or hands into the product.
- Use of an attachment not recommended or sold by the product manufacturer may result in a risk of fire, electric shock, or injury to persons.
- To reduce risk of damage to the electric plug and cord, pull the plug rather than the cord when disconnecting the product.
- Do not use the product in excess of its output rating. Overload outputs above the rating may result in a risk of fire or injury to persons.
- Do not use the product or attachment that is damaged or modified. Damaged or modified batteries may exhibit unpredictable behavior resulting in fire, explosion, or risk of injury.
- Do not operate the product with a damaged cord or plug, or a damaged output cable.
- Do not disassemble the product. Take it to a qualified service person when service or repair is required. Incorrect reassembly may result in a risk of fire or electric shock.
- Do not expose the product to fire or high temperatures. Exposure to fire or temperatures above 130°C may cause an explosion.
- To reduce the risk of electric shock, unplug the power pack from the outlet before attempting any instructed servicing.
- Have servicing performed by a qualified repair person using only identical replacement parts. This will ensure that the safety of the product is maintained.
- When charging a device, the product may feel warm. This is a normal operating condition and should not be a cause for concern.
- When charging the internal battery, work in a well-ventilated area and do not restrict ventilation in any way.
- Do not clean the product with harmful chemicals or detergents.
- Misuse, dropping, or excessive force may cause product damage.
- When disposing of secondary cells or batteries, keep cells or batteries of different electrochemical systems separate from each other.
- Do not use or store this product in direct sunlight for a long period, such as in a car, cargo bed, or any other place where it will be exposed to high temperatures. Doing so may cause the product to malfunction, deteriorate, or generate heat.
- Servicing of batteries should be performed or supervised by personnel knowledgeable about batteries and the required precautions.
- Do not use this product near strong static electricity or strong magnetic fields.
- Do not expose this product to flammable, explosive gas, or smoke.
- Do not stand on the product.
- Do not immerse the product in water. If the product accidentally falls into water, place it in a safe, open place and keep it away from fire until it is completely dry.
- Please deal with the scraps according to the regulations. For more details, please follow the local laws and regulations on battery recycling and disposal.

RoHS

