

Asymmetrical Horn™ 45°

COMPACT 5 GHz ASYMMETRICAL HORN ANTENNA

HG4-TP-A45 provides unique set of features. It combines compact form factor with asymmetrical beam pattern, TwistPort™ proprietary connector and advanced mounting system.

HG4-TP-A45 excels in environment where space is limited, such as dense cluster deployments or micro-PoPs. Asymmetrical beam pattern provides 17 dBi of Gain together with excellent noise immunity. Antenna is very compact, lightweight and easy to install thanks to UBR mount and integrated handle.



TECHNICAL DATA

Antenna Connection	TwistPort™ Waveguide Port
Antenna Type	Asymmetrical Horn
Materials	UV Resistant ABS Plastic, Polyethylene, Aluminum, Stainless Steel
Environmental	IP55
Flame Rating	UL 94 HB
Pole Mounting Diameter	30-80 mm (1.1-3.1 inch) Recommend as close to 80 mm (3.1inch) as possible
Temperature	-30°C to +55°C (-22°F to +131°F)
Wind Survival	180 km/h (110 mph)
Wind Load	30/41 N - Front/Side at 160 km/h (100 mph)
Effective Projected Area	247/335 cm ² - Front/Side (38.3/51.9 inch ²)
Mechanical Tilt	± 25°
Weight	Product: 2.53 kg / 5.6 lbs Product in Retail Box: 3.40 kg / 7.5 lbs Carton: 18.50 kg / 40.8 lbs
Single Unit	Retail Box: 280 x 255 x 255 mm / 11 x 10 x 10 inch
5 Units	Carton Box: 1.290 x 300 x 285 mm / 50.8 x 11.8 x 11.2 inch

PRODUCT DIMENSIONS

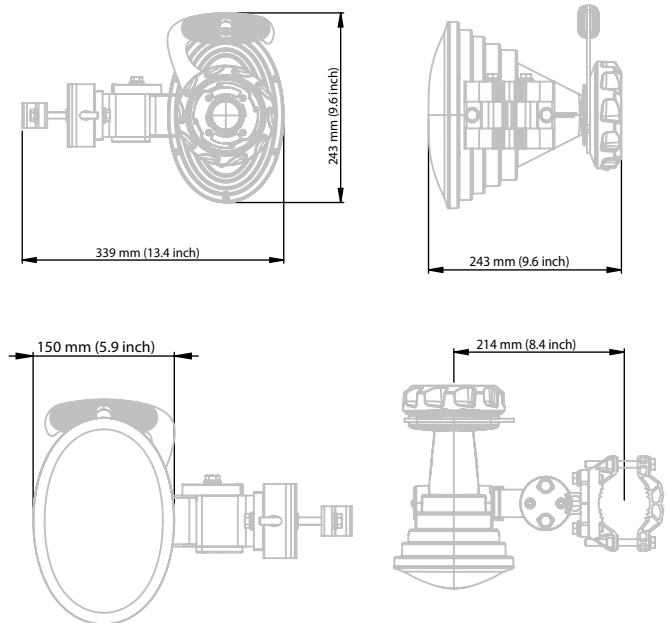

PERFORMANCE

Frequency Range	5150 - 6400 MHz
Gain	17 dBi
Azimuth Beam Width -3 dB	H 31° / V 30°
Elevation Beam Width -3 dB	H 21° / V 20°
Azimuth Beam Width -6 dB	H 44° / V 45°
Elevation Beam Width -6 dB	H 30° / V 29°
Beam Efficiency*	90 %
Front-to-Back Ratio	30 dB

POLAR PATTERNS

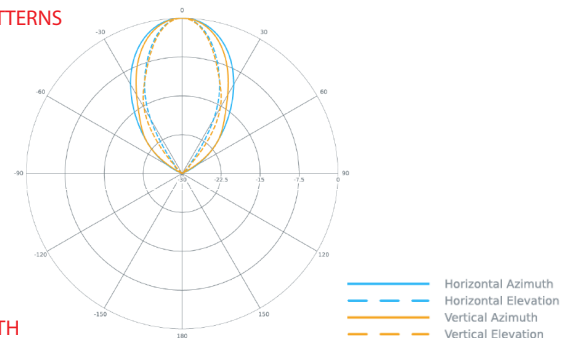

COMPATIBLE WIRELESS PLATFORMS

Any TwistPort™ compatible TPA or radio unit operating in dedicated frequency band

*Main beam defined up to the first null

BEAMWIDTH

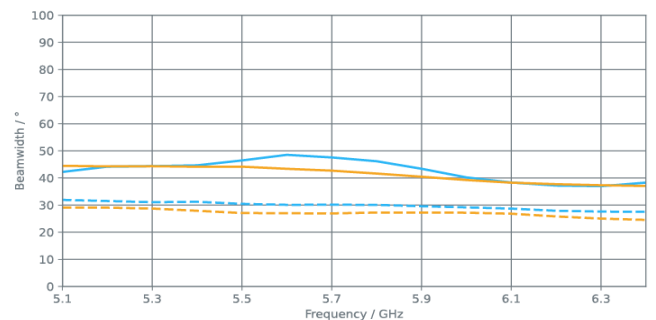

GAIN

