

LYNX L15 Handheld Thermal Monocular Camera



HIKMICRO L15 handheld thermal monocular camera is equipped with a 384 × 288 infrared detector and a 720 × 540 LCOS display. It supports functions of observation, distance measurement, Wi-Fi hot spot, and so on. The high-sensitivity built-in thermal detector provides you with clear view even in total darkness. The monocular is mainly applied to scenarios such as patrolling, searching and rescuing, hiking, travel, and hunting, etc.

Key Features

- 384 × 288 resolution, high sensitivity detector
- Adaptive AGC, DDE, 3D DNR, NETD less than 35 mK (@25 °C), F#=1.0
- 720 × 540 resolution 0.2-inch LCOS display
- Built-in rechargeable lithium battery
- More than seven hours continuous running (with Wi-Fi hot spot function off)
- Wi-Fi hot spot
- Type-C Interface

Specification

▪ Specification

Thermal Module	
Image Sensor	VOx Uncooled Focal Plane Arrays
Resolution	384 × 288
Frame Frequency	50 Hz
Pixel Interval	17 μm
Response Waveband	8 μm to 14 μm
NETD	≤ 35 mK (@25°C), F#=1.1
Focal Length	15 mm
IFOV	1.13 mrad
Field of View	24.6° × 18.5° (H × V)
Aperture	F1.0
Image Display	
Monitor	0.2 inch, LCOS, 720 × 540
Palettes	Black Hot, White Hot, Red Hot, Fusion
Uniformity Correction	Auto, Manual, External Correction
Digital Zoom	1×, 2×, 4×, 8×
Smart Function	
Hot Track	Yes
Distance Measurement	Yes
Detection Range	529 m
System	
Storage	Built-in memory module (8 GB)
Record Video	Yes
Capture Snapshot	Yes
Wi-Fi	Yes
Standby Mode	Yes
Power Supply	
Battery Type	Rechargeable Lithium Battery
Battery Operating Time	7 hours continuous running with Wi-Fi hot spot function off (@25 °C) 5.5 hours continuous running with Wi-Fi hot spot function on (@25 °C)
Battery Capacity Display	Yes
General	
Power	5 VDC/2 A, 1.5 W, Type-C Interface
Work Temperature/Humidity	From -20 °C to 55 °C (-4 °F to 131 °F); Humidity: 90% or Less
Protection Level	IP67
Dimension	158.3 mm × 61 mm × 57 mm (6.23" × 2.40" × 2.24")
Weight	270 g (0.60 lb)

Available Model

HM-TS03-15XF/W-L15

Dimension

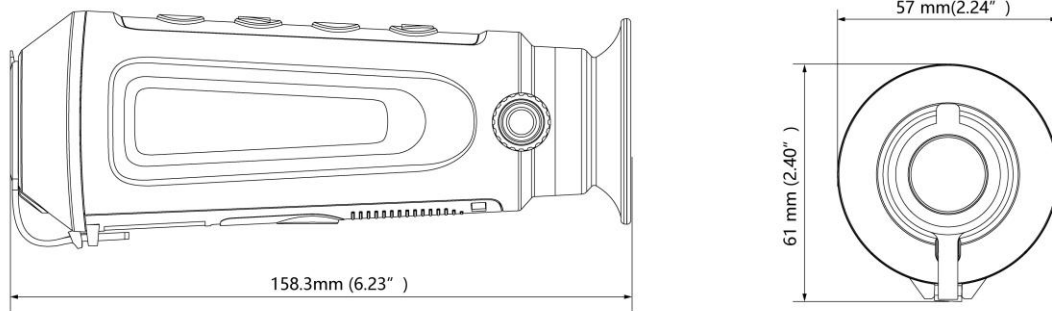

Accessory

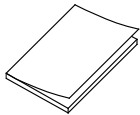

Quick Start Guide
(x1)

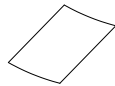

Non-dust Cloth (x1)



USB Cable (x1)



Protective Bag (x1)



Wrist Strap (x1)

COMPLIANCE NOTICE: The thermal series products might be subject to export controls in various countries or regions, including without limitation, the United States, European Union, United Kingdom and/or other member countries of the Wassenaar Arrangement. Please consult your professional legal or compliance expert or local government authorities for any necessary export license requirements if you intend to transfer, export, re-export the thermal series products between different countries.